

# Keysight N6783A-BAT and N6783A-MFG Application-Specific Modules

Series N6700  
Addendum

## Notice

© Keysight Technologies, Inc. 2011, 2018

No part of this document may be photocopied, reproduced, or translated to another language without the prior agreement and written consent of Keysight Technologies, Inc. as governed by United States and international copyright laws.

The material contained in this document is provided “as is,” and is subject to being changed, without notice, in future editions. Further, to the maximum extent permitted by applicable law, Keysight disclaims all warranties, either express or implied, with regard to this manual and any information contained herein, including but not limited to the implied warranties of merchantability and fitness for a particular purpose. Keysight shall not be liable for errors or for incidental or consequential damages in connection with the furnishing, use, or performance of this document or of any information contained herein. Should Keysight and the user have a separate written agreement with warranty terms covering the material in this document that conflict with these terms, the warranty terms in the separate agreement shall control.

## Contents

<b>About this Addendum .....</b>	<b>3</b>
<b>Module Features .....</b>	<b>3</b>
<b>Installation .....</b>	<b>3</b>
<b>Current Limit Modes .....</b>	<b>4</b>
<b>Protection Functions.....</b>	<b>4</b>
<b>SCPI Commands .....</b>	<b>5</b>
<b>Specifications and Characteristics .....</b>	<b>7</b>
<b>Verification and Calibration .....</b>	<b>10</b>

## About this Addendum

This addendum contains information specific to Keysight Models N6783A-BAT and N6783A-MFG. The addendum must be used in conjunction with the standard Keysight Series N6700 and N6705 User's Guides and Service Guides.

The web contains the most up to date User's Guide and Service Guide. Go to <http://www.Keysight.com/find/N6700> or <http://www.Keysight.com/find/N6705> to get the latest manuals.

## Module Features

Keysight Technologies Models N6783A-BAT and N6783A-MFG are Keysight Series N6700 and N6705 compatible power modules with basic, two-quadrant output characteristic (+V/+I and +V/-I) and a second current measurement range for improved measurement accuracy at low current levels. Both models support Option 761 - Output Disconnect Relay.

<b>Output Ranges</b>	N6783A-BAT Voltage range: 8 V, with a separate 12-bit DAC. N6783A-MFG Voltage range: 6 V, with a separate 12-bit DAC. Current range +3 A/-2A, with a separate 12-bit DAC. Note that the Negative output current is not programmable on N6783A-MFG.
<b>Measurement Ranges</b>	N6783A-BAT Voltage range: 8 V, with a 16-bit ADC. N6783A-MFG Voltage range: 6 V, with a 16-bit ADC. Current ranges: +3 A and 150 mA, using the same 16 bit ADC.
<b>Two Quadrant Operation</b>	Quadrant operation is modeled as a voltage priority loop with positive and negative current limits. Only the voltage priority loop can generate transient waveforms, so current waveforms are not supported.
<b>Positive OVP Delay</b>	The OVP has a user-programmable delay that can be used to prevent nuisance tripping for short-duration voltage overshoots.
<b>Negative Voltage Protection</b>	Negative voltage protection detects negative voltages and opens the + output terminal. This protection is latching, which requires a command to reset it. Negative voltage protection is shown as OV- on the front panel.

### NOTE

Arbitrary waveform generation and List programming are unavailable on the negative current output.

## Installation

Installation procedures for the Keysight N6783A-BAT and N6783A-MFG power modules are the same as for the standard power modules as described in the Keysight Series N6700 and N6705 User's Guides.

## Current Limit Modes

When operating in current limit mode, the power module regulates the output current at the selected value, while the output voltage varies as required by the load.

The power module can be operated in either positive current limit mode, or in negative current limit mode. When operating in positive current limit mode, the output is sourcing current. When operating in negative current limit mode, the output is sinking current. Whether the output sources or sinks current is determined by the output load.

Set the current limits as follows:

Front Panel:	SCPI Command:
N6700 – Press the <b>Menu</b> key, then select <b>Output\Current</b> .	To set a current limit of +1 A for output 1:
N6705 – Press the <b>Settings</b> key.	<code>CURR:LIM 1, (@1)</code>
To set the positive current limit, enter a value in the + Current Limit box.	To set a current limit of –1 A for output 1:
To set the negative current limit, enter a value in the – Current Limit box.	<code>CURR:LIM -1, (@1)</code>

### NOTE

The negative output current is not programmable on Model N6783A-MFG.

The negative current is determined by the load, with the maximum current limited to –2 amperes.

In positive current limit mode, the CL+ indicator on the front panel illuminates. In negative current limit mode, the CL– indicator on the front panel illuminates.

## Protection Functions

Each output has independent protection functions. A front panel status indicator will turn on when a protection function has been set. Protection functions are latching, which means that they must be manually cleared once they have been set.

Of the following protection functions, only OVP Delay is user-programmable.

<b>Positive OVP Delay</b>	Over-voltage protection delay is a hardware OVP whose trip level is a programmable value. The OVP delay is always enabled.
<b>Negative Voltage</b>	Negative voltage protection protects the output from negative voltages by opening the + output terminal and disabling the output. This is a latching protection that requires a sending a protection clear command to reset it. Status is annunciated on the front panel as "OV-" and in the OV- bit of the QUESTIONABLE status registers

## Set the Over-Voltage Protection Delay

The over-voltage protection function turns off the affected output if the output voltage reaches the programmed over-voltage limit. The output voltage is monitored at the + output and – output terminals.

The over-voltage protection includes a programmable delay that can be used to prevent nuisance tripping for short duration voltage overshoots. The delay range is 60 microseconds to 5 milliseconds from the occurrence of an over-voltage condition to the start of the output shutdown. The delay resolution is 20.48 microseconds.

Front Panel:	SCPI Command:
N6700 – Press the <b>Menu</b> key, then select <b>Protect\OVP</b> .	To set an OVP delay of 10 ms for output 1:
N6705 – Press the <b>Settings</b> key, then select <b>Protection</b> .	VOLT:PROT:DEL 0.01, (@1)
Enter a value in the OVP Delay box.	

Note that the overvoltage protection delay does not apply to the reverse voltage protection function.

## SCPI Commands

The following SCPI commands apply to models N6783A-BAT and N6783A-MFG.

SCPI Command	Description
CALibrate :CURRent :LIMit :NEGative <NRf>,(@<channel>)	Calibrate the negative current limit.
[SOURce] :CURRent :LIMit [:POSitive] [:IMMEDIATE][:AMPLitude] <NRf+>,(@<chanlist>)	Set positive current limit
:NEGative [:IMMEDIATE][:AMPLitude] <NRf+>,(@<chanlist>)	Set negative current limit (only on model N6783A-BAT)
:VOLTage :PROtection :DELay[:TIME] <NRf+>,(@<chanlist>)	Set OVP delay time

## **CALibrate:CURRent:LIMit:NEGative**

CALibrate:CURRent:LIMit:NEGative <value>, (@<channel>)

This command initiates calibration of the negative current limit. The value is programmed in amperes and must be specified as negative. The value that you enter selects the range that is being calibrated. There is only one negative current range.

## **CURRent:LIMit:NEGative**

[SOURce:]CURRent:LIMit:NEGative[:IMMEDIATE][:AMPLitude] <value>[MIN|MAX, (@<chanlist>)]  
[SOURce:]CURRent:LIMit:NEGative[:IMMEDIATE][:AMPLitude]? [MIN|MAX,] (@<chanlist>)

*This command only applies to model N6783A-BAT.*

This command sets the negative current limit of the output channel. The value is programmed in amperes. The programming range is from 0 to -2 A. MIN or MAX may also be programmed.

The \*RST value = -2 (for N6783A-BAT only)

## **CURRent:LIMit[:POSitive]**

[SOURce:]CURRent:LIMit[:POSitive][:IMMEDIATE][:AMPLitude] <value>[MIN|MAX, (@<chanlist>)]  
[SOURce:]CURRent:LIMit[:POSitive][:IMMEDIATE][:AMPLitude]? [MIN|MAX,] (@<chanlist>)

This command sets the positive current limit of the output channel. The value is programmed in amperes. The programming range is from 0 to 3 A. MIN or MAX may also be programmed. This command is aliased with [SOURce:]CURRent <value>, (@<chanlist>).

The \*RST value = MAX

## **VOLTage:PROTection:DELAy**

[SOURce:]VOLTage:PROTection:DELAy[:TIME] <value>[MIN|MAX, (@<chanlist>)]  
[SOURce:]VOLTage:PROTection:DELAy[:TIME]? [MIN|MAX,] (@<chanlist>)

This command sets the over-voltage protection (OVP) delay of the output channel. This prevents momentary changes in output voltage from triggering the over-voltage protection. Over-voltage protection will not be triggered on the specified output channel during the delay time. After the delay time has expired, the over-voltage protection function will be active. The delay time is programmed in seconds, from 60 microseconds to 5 milliseconds with a resolution of 20.48 microseconds. MIN or MAX may also be programmed.

The \*RST value = 0

# Specifications and Characteristics

Unless otherwise noted, specifications will be warranted over the ambient temperature range of 0 to 40°C after a 30-minute warm-up period, with each module's sense terminals externally jumpered directly to their respective output terminals (local sensing).

Supplemental characteristics are not warranted but are descriptions of performance determined either by design or type testing. All supplemental characteristics are typical unless otherwise noted.

## Performance Specifications

	N6783A-BAT	N6783A-MFG
<b>DC Output Ratings:</b>		
Voltage	8 V	6 V
Current <sup>NOTE 1</sup>	- 2 A to +3 A	- 2 A; 0 to +3 A
Power	24 W	18 W
<b>Output Ripple and Noise (PARD):</b> (from 20 Hz – 20 MHz)		
CV peak-to-peak	8 mV	8 mV
CV rms	1.5 mV	1.5 mV
<b>Load Effect (Regulation):</b> (for any output load change, with a maximum load-lead drop of 0.5V/lead)		
Voltage	6 mV	6 mV
Current	2 mA	2 mA
<b>Source Effect (Regulation):</b>		
Voltage	2 mV	2 mV
Current	1 mA	1 mA
<b>Programming Accuracy:</b> (@ 23 °C ±5 °C after a 30 minute warm-up)		
Voltage	0.1% + 10 mV	0.1% + 10 mV
Positive Current	0.1% + 1.8 mA	0.1% + 1.8 mA
Negative Current @ -2 A	0.2% + 1.8 mA	N/A
<b>Measurement Accuracy:</b> (@ 23 °C ±5 °C)		
Voltage <sup>NOTE 2</sup>	0.05% + 5 mV	0.05% + 5 mV
Current high range <sup>NOTE 2</sup>	0.1% + 600 µA	0.1% + 600 µA
Current low range (≤ 150mA) <sup>NOTE 2</sup>	0.1% + 75 µA	0.1% + 75 µA
<b>Load Transient Recovery</b> (Time to recover to within settling band for a load change from 0.15 A to 1.5 A and from 1.5 A to 0.15 A at 6 V output.)		
Voltage settling band <sup>NOTE 3</sup>	± 75 mV	± 75 mV
Time <sup>NOTE 3</sup>	< 45 µs	< 45 µs

<sup>1</sup> Output current is derated 1% per °C above 40°C.

<sup>2</sup>Applies when measuring the default value of 1024 data points

<sup>3</sup> When relay Option 761 is installed, the settling band is ± 90 mV. The time is < 75 µs.

## Supplemental Characteristics

	N6783A-BAT	N6783A-MFG
<b>Programming Ranges:</b>		
Voltage	15 mV to 8.16 V	15 mV to 6.12 V
Positive Current	5 mA to 3.06 A	5 mA to 3.06 A
Negative Current	- 5 mA to - 2 A	Fixed at - 2 A
<b>Programming Resolution:</b>		
Voltage	2.5 mV	2.5 mV
Positive Current	1 mA	1 mA
Negative Current	10 mA	N/A
<b>Measurement Resolution:</b>		
Voltage	300 $\mu$ V	300 $\mu$ V
Current high range	100 $\mu$ A	100 $\mu$ A
Current low range ( $\leq 0.150$ A)	5 $\mu$ A	5 $\mu$ A
<b>Programming Temperature Coefficient per <math>^{\circ}</math>C:</b>		
Voltage	25 ppm + 50 $\mu$ V	25 ppm + 50 $\mu$ V
Current	25 ppm + 10 $\mu$ A	25 ppm + 10 $\mu$ A
<b>Measurement Temperature Coefficient per <math>^{\circ}</math>C:</b>		
Voltage	25 ppm + 40 $\mu$ V	25 ppm + 40 $\mu$ V
Current high range	25 ppm + 2.5 $\mu$ A	25 ppm + 2.5 $\mu$ A
Current low range ( $\leq 0.150$ A)	25 ppm + 1.5 $\mu$ A	25 ppm + 1.5 $\mu$ A
<b>Maximum Up-Programming and Down-Programming Time with Full Resistive Load</b> (time from 10% to 90% of total voltage excursion)		
Voltage Settling from 0V to Full Scale	4.0 ms	4.0 ms
Voltage Settling from Full Scale to 0V	4.0 ms	4.0 ms
<b>Maximum Up-Programming and Down-Programming Settling Time with Full Resistive Load</b> (time from start of voltage change until voltage settles within 0.1% of the full-scale voltage of its final value)		
Voltage Settling from 0V to Full Scale	20 ms	20 ms
Voltage Settling from Full Scale to 0V	20 ms	20 ms
<b>Over-voltage Protection:</b>		
Accuracy without disconnect relays	0.25% + 75 mV	0.25% + 75 mV
Accuracy with disconnect relays	0.25% + 275 mV	0.25% + 275 mV
Nominal range	0 - 10 V	0 - 10 V
Programmable delay time	60 $\mu$ s - 5 ms (from occurrence of over-voltage condition to start of output shutdown)	
<b>Over-Current Protection:</b>		
Programmable delay time	0 - 255 ms	0 - 255 ms
Nominal Range	5 mA - 3.06 A	5 mA - 3.06 A
<b>Output Ripple and Noise: (PARD)</b>		
CC rms:	4 mA	4 mA
<b>Common Mode Noise:</b> (from 20 Hz - 20 MHz; from either output to chassis)		
Rms	1 mA	1 mA
Peak-to-peak	6 mA	6 mA



### Supplemental Characteristics (continued)

	N6783A-BAT	N6783A-MFG
<b>Remote Sense Capability:</b>	Outputs can maintain DC specifications with up to a 0.5-volt drop per load lead. Maximum sense lead resistance is limited to 300mΩ/lead.	
<b>Series and Parallel Operation:</b>	Identically rated outputs <b>can</b> be operated directly in parallel. N6783A modules <b>cannot</b> be used in series with other N6783A modules or any other N67xx module. Auto-series and auto-parallel operation is not available.	
<b>Down-programming Capability:</b>		
Continuous power	12 W	12 W
Continuous current (applies above 0.50 V output)	2 A	2 A

### Output Quadrant Characteristic

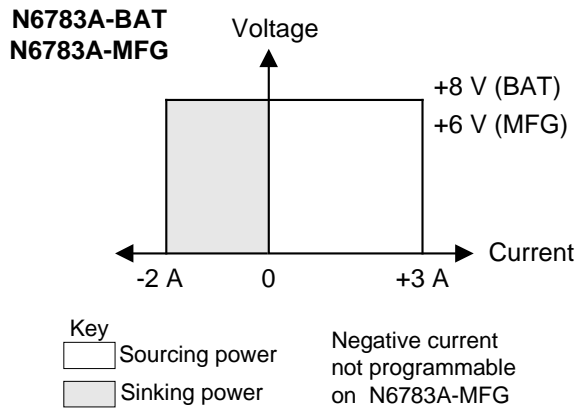

# Verification and Calibration

## Verification

Verification consists of performing the following steps as described in the Keysight Series N6700 and N6705 Service Guides:

- Voltage Programming and Readback Accuracy
- CV Load Effect
- CV Source Effect
- CV Ripple and Noise
- Transient Recovery Time (see below)
- Current Programming and Readback Accuracy
- CC Load Effect
- CC Source Effect
- Negative Current Output (see below)

The Transient Recovery Time procedure described below differs from the procedure documented in the Keysight Series N6700 and N6705 Service Guides. Also, the Negative Current Output procedure must be added to the verification procedures described in the Service Guides. This only applies to Keysight Models N6783A-BAT and N6783A-MFG.

### Transient Recovery Time

*Test category = performance*

This test measures the time for the output voltage to recover to within the specified value following a 0 to 50% change in the load current. The Keysight N6782A generates the load current pulse.

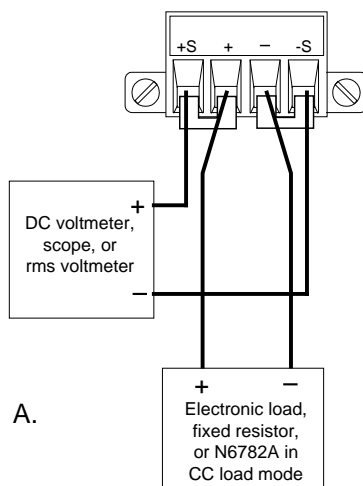

- 1 Turn off the power system and connect an oscilloscope across the sense terminals (see Test Setup A). Connect an Keysight N6782A SMU as a load to the output terminals.
- 2 Turn on the power system and program the Model N6783A instrument settings as described in the test record form under “Transient Response 6V”.
- 3 Set the Model N6782A that is being used as the load as follows:
  - a. Emulation Mode = CC Load (in current priority mode)
  - b. + Voltage limit = 6.12 V
  - c. Current Slew = 67500 A/s (for a pulse rise/fall time of 20  $\mu$ s)
  - d. Arb = Current Pulse
  - e. Load pulse properties:  
 $I_0 = -0.15$  A;  $I_1 = -1.5$  A;  $T_0 = 0.005$ ;  $T_1 = 500$  E-6;  $T_2 = 0.005$ ;
  - f. Continuous = ON
  - g. Press Arb run.

**Note:** Use LIST commands to program the load current pulse when the N6782A is installed in an N6700 MPS mainframe.

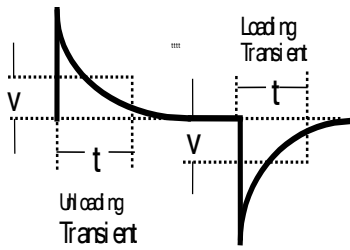

- 4 Adjust the oscilloscope for a waveform similar to that shown in the figure on the left.
- 5 The output voltage should return to within the specified voltage at the specified time following the 0 to 50% load change. Check both loading and unloading transients by triggering on the positive and negative slope. Record the voltage at time “t” in the performance test record form under “Transient Response 6V”.

### Negative Current Output

*Test category = performance, calibration*

This test verifies the negative current output.

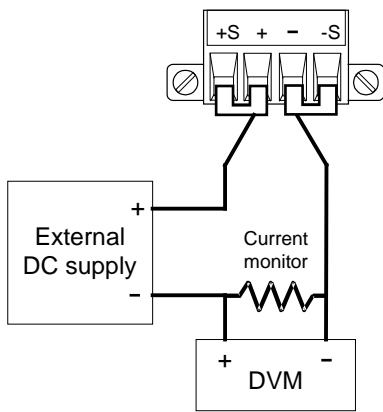

- 1 Connect the DVM, current shunt, and a power supply to the output as shown in the Negative Current Test Setup figure on the left. Connect plus to plus, minus to minus. Set the external power supply to 3V, 3A.
- 2 Program the Model N6783A instrument settings to the values indicated in the Test Record Form under “Negative Current Output”. The display should read approximately -2 A.
- 3 Divide the voltage drop (DVM reading) across the current shunt by its resistance to convert to amperes and record this value. The reading should be within the limits specified on the Test Record Form under “Constant Current Tests, Negative Current Output”.

## Test Record Form – Keysight N6783A-BAT and N6783A-MFG

Keysight N6783A-BAT, N6783A-MFG Description	Report No _____ Model	Date _____ Minimum Specs.	Results	Maximum Specs.
<b>Constant Voltage Tests</b>				
<b>Voltage Programming &amp; Readback</b>				
Minimum Voltage Vout	Both	+5 mV	_____	+25 mV
Voltage measured over interface	Both	Vout – 5 mV	_____	Vout + 5 mV
High Voltage Vout	N6783A-BAT	7.982 V	_____	8.018 V
	N6783A-MFG	5.984 V	_____	6.016 V
Voltage measured over interface	N6783A-BAT	Vout – 9 mV	_____	Vout – 9 mV
	N6783A-MFG	Vout – 8 mV	_____	Vout + 8 mV
<b>CV Load Effect</b>				
	Both	– 6 mV	_____	+ 6 mV
<b>CV Source Effect</b>				
	Both	– 2 mV	_____	+ 2 mV
<b>CV Ripple and Noise</b>				
peak-to-peak	Both	N/A	_____	+ 8 mV
rms		N/A	_____	+ 1.5 mV
<b>Transient Response 6 V</b>				
Voltage at 45 $\mu$ s	Both	– 75 mV	_____	+ 75 mV
Voltage at 75 $\mu$ s with Option 761	Both	– 90 mV	_____	+ 90 mV
<b>Constant Current Tests</b>				
<b>Current Programming &amp; Readback</b>				
Minimum Current Iout	Both	– 3.2 mA	_____	+ 6.8 mA
Current measured over interface	Both	Iout – 0.6 mA	_____	Iout + 0.6 mA
High Current Iout	Both	2.9952 A	_____	3.0048 A
Current measured over interface	Both	Iout – 3.6 mA	_____	Iout + 3.6 mA
Low Current measured over interface	Both	Iout – 90 $\mu$ A	_____	Iout + 90 $\mu$ A
<b>CC Load Effect</b>				
	Both	– 2 mA	_____	+ 2 mA
<b>CC Source Effect</b>				
	Both	– 1 mA	_____	+ 1 mA
<b>Negative Current Output</b>				
	Both	– 1.9942 A	_____	– 2.0058 A

Test Description	N6783A-BAT Setting	N6783A-MFG Setting
Voltage Programming & Readback, Min	15 mV, 3 A	15 mV, 3 A
Voltage Programming & Readback, High	8 V, 3 A	6 V, 3 A
CV Load Effect, Source Effect, Ripple and Noise	8 V, 3 A	6 V, 3 A
Transient Response 6 V	6 V, from 0.15 A to 1.5 A	6 V, from 0.15 A to 1.5 A
Current Programming & Readback, Min	5 mA, 8 V	5 mA, 6 V
Current Programming & Readback, High	3 A, 8 V	3 A, 6 V
Current Readback, Low	150 mA, 8 V	150 mA, 6 V
CC Load Effect, Source Effect	3 A, 8 V	3 A, 6 V
Negative Current Output	0 V, –2A	0 V, –2A

## Calibration

Calibration consists of performing the following steps as described in the Keysight Series N6700 and N6705 Service Guides:

- Voltage Programming and Measurement Calibration –as described under Models N673xB, N674xB, N677xA.
- Current Programming and Measurement Calibration - as described under Models N673xB, N674xB, N677xA.
- Low Range Current Measurement Calibration (see below)
- Negative Current Limit Calibration (see below)

The Low Range Current Measurement Calibration described below differs from the procedure documented in the Keysight Series N6700 and N6705 Service Guides. Also, the Negative Current Limit Calibration must be added to the calibration procedures described in the Service Guides. This only applies to Keysight Models N6783A-BAT and N6783A-MFG.

### Low Range Current Measurement Calibration

**Step 1.** Connect only the current measurement terminals of the Keysight 3458A to the output terminals. From the instrument's front panel program 60 power line cycles per measurement. Press NPLC 60 ENTER.

**Step 2.** Select the low current measurement range. The value to program a range must be the maximum current of the range. This example selects the 0.15 A range of output 1.

Front Panel:	SCPI Command:
N6700 – From the Calibration menu, select <b>Curr\Imeas\Low1</b> . Then select Next.	CAL:CURR:MEAS 0.15, (@1)
N6705 – From the Calibration menu, select <b>Current\Low Range Measurement</b> . Then select Start.	

**Step 3.** Select the first current calibration point.

Front Panel:	SCPI Command:
The information field should indicate: Enter P1 measured data.	CAL:LEV P1 *OPC?

**Step 4.** Measure the current with the Keysight 3458A and enter the value.

Front Panel:	SCPI Command:
Enter the data from the external DMM into the Measured Data field. Press Select or Enter when done. Exit the calibration sequence.	CAL:DATA <data> *OPC?

## Negative Current Limit Calibration

- Step 1.** Connect the DVM, current shunt, and a power supply to the output as shown in the previous Negative Current Output figure. Connect plus to plus, minus to minus. Set the external power supply to 3V, 3A.
- Step 2.** Select the negative-current range. The value to select the range must be negative and the maximum current of the range.

Front Panel:	SCPI Command:
N6700 – From the Calibration menu, select <b>Curr\Lim</b> . Then select Next.	CAL:CURR:LIM:NEG -2, (@1)
N6705 – From the Calibration menu, select <b>Current\ Current Limit</b> . Then select Start.	

- Step 3.** Select the first current calibration point.

Front Panel:	SCPI Command:
The information field should indicate: Enter P1 measured data.	CAL:LEV P1

- Step 4.** Calculate the shunt current ( $I=V/R$ ); enter the *negative* current value.

Front Panel:	SCPI Command:
Enter the data from the external DMM into the Measured Data field. Press Select or Enter when done. Press Next to continue.	CAL:DATA <data>*OPC?

- Step 5.** Select the second current calibration point.

Front Panel:	SCPI Command:
The information field should indicate: Enter P2 measured data.	CAL:LEV P2

- Step 6.** Calculate the shunt current ( $I=V/R$ ); enter the *negative* current value.

Front Panel:	SCPI Command:
Enter the data from the external DMM into the Measured Data field. Press Select or Enter when done. Exit the calibration sequence.	CAL:DATA <data>*OPC?